



# **INSTRUCTION MANUAL**

**Air operated double diaphragm pumps**  
**Version 7.17**

**Models: SEMI T**

**SEMI H**

**SEMI E**

**SEMI S**

Serial no.

# DECLARATION OF CONFORMITY

**Directive 2006/42/EC, Annex 2A**

Company: **DELLMECO LTD**

Address: **Unit 1, Willow Row  
Longton, Stoke on Trent  
Staffordshire, ST3 2PU, United Kingdom**

**declares under our sole responsibility, that the product:**

Product name: **Air Operated Double Diaphragm Pumps**

Models: **DMS - series**

Referred to in this declaration conforms with the:

**- Directive 2006/42/EC**

Date: **June 2<sup>nd</sup> 2014**



**K. Ziemann  
Managing Director**

## General information

The pumps from SEMI series have been designed especially for the purpose of semiconductor industry. The whole assembly process of these unique products is completed in a class 100 clean room, involving a double cleaning of the parts, their testing with de-ionized water, and finally sealing in plastic foils.

Due to specific features of the product, the following manual must be studied carefully before mounting and operating a pump, regardless of experience that a user may have. The numbers in square brackets, used throughout the manual, refer to the numbers of parts as presented in the technical scheme (see page 11).

The detailed procedure of assembly of the pump is given in the further part of the manual, together with a technical drawing. In case of any doubt or difficulty, please contact DELLMECO immediately.

## Commissioning operations

All parts of the SEMI T and SEMI H pumps coming in touch with liquids are made of PTFE. The housing parts of the SEMI E pump coming in contact with liquids are made of UPPE (ultra pure polyethylene). The housing parts of SEMI S pump coming in contact with liquid are made of AISI 316L stainless steel. Therefore it must be checked that any liquid to be used in the pump comply with the construction materials.

**In case of the SEMI E pump, it is an absolute must to obey the limits set to operating pressure (max. 6 bar) and the temperature of a liquid (max. 70°C).** In case of the SEMI T, SEMI H or SEMI S pumps, the temperature limits and dependable driving pressure are different. The chart below presents maximum permissible values.

Driving air pressure	6 bar	5 bar	4 bar	3 bar	2 bar
SEMI T : max. permissible temperature	100°C	110°C	120°C	130°C	130°C
SEMI H : max. permissible temperature	100°C	130°C	150°C	180°C	200°C
SEMI S : max. permissible temperature	130°C	130°C	130°C	130°C	130°C

! After the pump has run for the first few hours, it is necessary to check the union nuts [9] for tightness. This must be done before a full start-up. If needed, tighten the nuts. A similar check-up should be carried out after each longer stoppage, transportation, disassembly or when huge variations of temperature were in use.

## Connection to the piping system

The SEMI pumps are installed with anchor bolt bushings [20] or they stand free.

! Remember that the pumps must not be treated as a fixed point for the piping and that they must be always connected free of load. Otherwise leakage or damage may follow!

- ! When the pump is installed into the piping where vibrations are unavoidable, it is strongly advised to mount the compensators either downstream or upstream the pump.

### **Suction and discharge lines**

In deciding on the width of the connection pipes, keep in mind the nominal port size of the pump.

If the piping size is smaller than required, cavitation may appear in the suction line, or the performance of both the suction and discharge lines can deteriorate. If the piping size is bigger than required, the dry suction capacity may be lowered. The chart below presents the nominal port sizes for the pumps.

Pump size	10	20	50	100
Nominal port size	3/8"	1/2"	1"	1 1/4"

- ! The center housing [2] has two ports – the lower is meant for the suction piping, the upper for the discharge piping. It is not permissible to reverse the ports!

In order to avoid air bubbles and possible performance problems, the suction line should have a steady upward gradient. Optionally, Flaterrek® connectors for PFA pipes can be used (see the section on special equipment, code CF).

### **Air supply**

In order to ensure sufficient driving air, an adequate air-supply line must be submitted. This conditions a proper operative sufficiency of the pump. The air-supply piping must be at least the same as the nominal width of pump connection (G 1/4"). The diagram below presents the location of the connection for compressed air (the left side of the housing [1], opposite the muffler [17]).

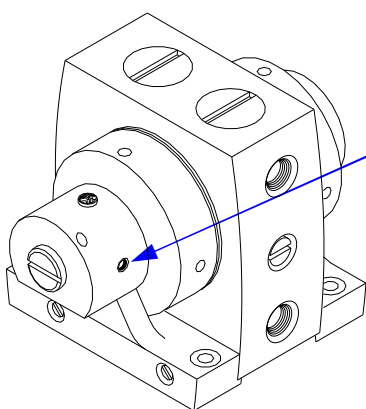

If the pump is installed in any kind of locked space (boards, cabinets, etc.), the cold air mustn't be halted behind the muffler.

The driving air is supplied dried. However, if the pump is installed in humid conditions, there can be outside icing occurring. In that case it is advisable to extend the air exhaust pipe or hose by additional 500 mm.

For optimal operation, you can use the integrated air control system of precise steering. It requires clean and oil-free compressed air that must comply with the following quality classes (given in ISO-DIS 8573-1):

water content:	class 3
oil content:	class 3
solids content:	class 2

## **Start-up**

The start-up is possible only after all the lines have been connected properly.

- ! Limit the driving air pressure to the needed level. Too high pressure will cause excessive air consumption and improper work of the pump.

The start-up of the pump is initiated automatically when the air supply is turned on.

To keep a steady flow, do not let the pressure drop lower than 1.5 bar. The flow rate of the pump is adjusted by a needle valve. Pre-filling the suction line or the pump itself is not required, as the SEMI pumps operate on self-priming principle. Remember, though, that a filled pump has a considerably higher capacity.

When empty, the pump must be driven slowly.

- ! In case of air-operated double-diaphragm pumps with a centered flow, avoid dry running for longer periods of time or at higher frequency. Otherwise damage may follow!

Avoid throttling or blocking the suction line. Damage may follow!

It is permissible to operate the pump for a short period of time with a closed discharge in order to test the pressure. If prolonged special operation of this or similar kind is required, check it first with the producer of the pump. It is not allowed, though, to carry out a pressure test of the installation in which the pump is set unless the both ports of the pump are disconnected – the pressure from the plant can be too high and is due to damage the pump! This kind of test can be done only when the pressure used is the operating pressure of the pump.

- ! Do not exceed the maximal permissible stroke frequencies during normal operation. Otherwise damage may follow. (Study the table below for the values of strokes allowed at nominal performance).

<b>Pump size</b>	<b>10</b>	<b>20</b>	<b>50</b>	<b>100</b>
Max number of strokes/ min. at nominal performance	400	320	210	240

If the diaphragm of the pump has been fractured in any way and the pump keeps operating, it is possible that the pump medium will come through the muffler. In that case stop the pump and check the diaphragm.

- ! Pneumatic diaphragm pumps must never be allowed to work with a positive suction pressure. It is against their construction principle and may lead to damage.

## **Rinsing procedure**

In order to clean the pump before disassembly, rinse it with a neutral product. Next turn the pump around to the top and rinse again. Then turn it to the side and rinse again. Finally turn back to the top and rinse again. Repeat these steps several times.

## **Disassembly**

To disassemble the pump, first disconnect both of the ports from the pressure, disconnect the air supply, empty the pump of the medium and rinse it thoroughly.



- If the medium used in the pump was toxic, hazardous or corrosive, the disassembly of the pump must be carried out in accordance with adequate safety regulations.

The steps for disassembly of the pump are as follows:

1. Remove the head screws [26, 33] on both sides of the pump with a screwdriver, remove the base frame [19], and take out air channel O-rings [25].
2. On the left side of the housing [1] remove the muffler [17] (in case of pump size 10 also the adapter muffler [30]) and the plug with O-ring [29].
3. Put a suitable round bar into one of the bore holes in the union nut [9] on the left side housing and with its help unscrew and remove the union nut [9] from the housing [1]. Then take the sliding ring [12] out of the left side housing [1], and take the union nut O-ring [10] out of the union nut [9].
4. Unscrew the air valve cover [32] from the left side housing [1] and then put the housing down flat on the side. The air control system [13] – except pilot piston – can be moved into the air valve cover side.
5. Take the diaphragm bolt piston rings [16] and then the pilot piston of the air control system out of the diaphragm bolt on the left [24].
6. Put a bar into one of the bore holes in the union nut [9] of the right side housing [6] and unscrew the union nut [9], then set apart the right side housing [6] and the union nut [9].
7. Take the sliding ring [12] out of the right side housing [6] and the union nut O-ring [10] out of the union nut [9].
8. Put the center housing [2] upright, with the connectors directed to the front. Take out the both diaphragm outer O-rings [7]. Separate the right and left diaphragm bolts [21, 24] from diaphragms [4]. Unscrew one of the diaphragms [4] out of the cascade sleeve [14] and then take out the other diaphragm [4] together with the cascade sleeve [14] and unscrew them.
9. If needed, replace the diaphragm inner O-ring [23] with a new one to prevent twisting. The diaphragm gaskets [8] must be replaced with no exception!
10. Put the center housing [2] upright unscrew both the discharge valve stops [27] at the top of the housing [2]. Take the check valves [5] out. Then unscrew the both suction valve stops [22] (one is situated at the front of the housing [2] between the connectors, the other one is at the back) and take the check valves [5] out.

## **Assembly**



After disassembly, no piston rings [16] or diaphragm gaskets [8] can be used again – new rings and gaskets must be set in!

- All damaged sealing parts must be replaced!

Remember that the newly changed diaphragm gaskets need some time to settle, therefore the assembly must be completed at least 2 hours before a start-up. After the two-hour rest tighten the both union nuts [9] - study the table below to check the nominal dimensions of the acceptable space between the outer edge of the union nut and the center housing.

<b>Pump size</b>	<b>10</b>	<b>20</b>	<b>50</b>	<b>100</b>
mm (tolerance +0.3/ -0.5 mm)	28,8	31,3	36,7	41,3

When tightening the nuts, be careful to keep the described lock-pin of the side housing **[1, 6]**, as well as the parallel array to the center housing **[2]**.



Moisten the O-rings before assembly to avoid their damaging!

Basically, assembly is carried out in reverse order to disassembly. The steps for assembly are as follows:

1. Move the air control system cartridge **[13]** back from the air valve cover into the left side housing **[1]**.
2. Screw the valve stops **[22, 27]** into the center housing **[2]** – make sure they match the surface and do not protrude above.
3. Put the center housing **[2]** on the left side and insert the diaphragm gasket **[8]**. Be careful not to fracture the gasket. Screw the right diaphragm bolt **[21]** into the diaphragm **[4]** and then screw the diaphragm **[4]** into the cascade sleeve **[14]**. Put the ready sleeve **[14]** into the center housing **[2]**. Finally place the diaphragm outer O-ring **[7]** in the diaphragm recess.
4. Put the right side housing **[6]** making sure that the straight surface with the bore holes for air is in a parallel position to lower part of the center housing **[2]**, and then insert the sliding ring **[12]**.
5. Insert the union nut O-ring **[10]** into the union nut **[9]**. Then put a bar into a bore hole of the right side housing **[6]** to make any rotation impossible, and screw the union nut **[9]** with the center housing **[2]**.
6. Place the diaphragm gasket into the left side housing **[1]**. Be careful not to fracture the gasket. Now use the air bore hole (in the middle) on the right side of the center housing **[2]** to treat the first installed diaphragm **[4]** from point 3 with the compressed air. Maintain the air stream until the other (left) diaphragm **[4]** is inserted into the center housing **[2]**. Screw the left diaphragm bolt **[24]** into the diaphragm **[4]**.
7. Place the air control system pilot piston **[13]** into the left diaphragm bolt **[24]**.
8. Assemble the left side housing **[1]** following the same procedure steps as in the case of the right side housing **[6]**.
9. Place the fifth air valve housing O-ring before closing and screwing the air valve cover **[32]**.
10. Screw in the muffler **[17]** and the plug with O-ring **[29]**.

## **Possible problems and their solutions**

Problem	Reason
The pump will not start.	<ul style="list-style-type: none"><li>• air supply line is blocked</li><li>• muffler is blocked</li><li>• assembly of diaphragms was defective</li><li>• air control is faulty</li></ul>
The pump operates, but suction doesn't work.	<ul style="list-style-type: none"><li>• suction line is blocked</li><li>• suction line leaks</li><li>• suction needed for the medium is higher than suction capacity of the pump</li></ul>
Air bubbles form in the pumped medium.	<ul style="list-style-type: none"><li>• diaphragm is fractured</li></ul>
The pump doesn't operate smoothly.	<ul style="list-style-type: none"><li>• diaphragm is fractured</li><li>• air control needs replacement</li></ul>
The pump stops operating.	<ul style="list-style-type: none"><li>• air pressure dropped too low</li><li>• air control is faulty</li><li>• air control is iced</li><li>• muffler is iced or blocked</li><li>• discharge line is blocked</li><li>• diaphragm is fractured</li><li>• pressure in the system is higher than driving pressure</li></ul>
Delivery falls down.	<ul style="list-style-type: none"><li>• air pressure dropped too low</li><li>• air control is iced</li><li>• muffler is blocked</li><li>• suction line is blocked</li><li>• discharge line is blocked</li><li>• viscosity of medium is not steady</li></ul>



**Technical details - independent of the pump model**

<b>Pump size</b>	<b>10</b>	<b>20</b>	<b>50</b>	<b>100</b>
Dimensions [mm], length	184	207	255	315
width	114	154	207	269
height	133	172	215	267
Nominal port size (NPS)	3/8"	1/2"	1"	1 1/4"
Max. capacity [l/min.]	10	20	50	100
Air connection (NPT)	1/4"			
Air classification (ISO-DIS 8573-1)				
solids	class 2	class 2	class 2	class 2
water	class 3	class 3	class 3	class 3
oil	class 3	class 3	class 3	class 3
Weight [kg]				
SEMI T	2,5	4,5	9	18
SEMI H	3,5	6	-	-
SEMI E	2	3	6	12
SEMI S	-	14	30	-
Suction head, dry [m.w.c.]	1	2,5	3,5	4
Suction head, with product [m.w.c.]	8	9	9	9
Max. permissible pressure driving [bar]	6	6	6	6
Max. sound pressure level acc. to DIN 45635, part 24, at maximum load [dB]	72	72	72	72

<b>Max. permissible temperature [°C]</b>				
<b>Pump model</b>	<b>SEMI T</b>	<b>SEMI H</b>	<b>SEMI E</b>	<b>SEMI S</b>
at max. 6 bar	100	100	70	130
at max. 5 bar	110	130	70	130
at max. 4 bar	120	150	70	130
at max. 3 bar	130	180	70	130
at max. 2 bar	130	200	70	130

## Spare part list

Pump size					DMS 10	DMS 20	DMS 50	DMS 100
Item	Pc.	Description	Pump code	Material	Part No.	Part No.	Part No.	Part No.
1	1	Side housing, left hand	T	UPPE	7 10 07 22	7 15 07 22	7 25 07 22	7 32 07 22
			E					
			H	PTFE	7 10 07 23	7 15 07 23	-	-
			S	PTFE conductive	-	7 15 07 24	7 25 07 24	-
2	1	Center housing	T	TFM/PTFE	7 10 10 05	7 15 10 05	7 25 10 05	7 32 10 05
			H					
			E	UPPE	7 10 10 22	7 15 10 22	7 25 10 22	7 32 10 22
			S	AISI 316L	-	7 15 510 53	7 25 510 53	-
3	4	Gasket, valve stop, check valve	T, H, E, S	PTFE	-	7 15 078 23	7 25 078 23	-
4	2	Diaphragm	T, H, E, S	TFM/PTFE	7 10 52 05	7 15 52 05	7 25 52 05*	7 32 52 05***
5	4	Check valve	T, H, S	TFM/PTFE	7 10 060 05	7 15 060 05	7 25 060 05*	7 32 060 05***
			E	UPPE	-	7 15 060 22	7 25 060 22	7 32 060 22
				TFM/PTFE	7 10 060 05**	-	-	-
6	1	Side housing, right hand	T, E	UPPE	7 10 06 22	7 15 06 22	7 25 06 22	7 32 06 22
			H	PTFE	7 10 06 23	7 15 06 23	7 25 06 23	7 32 06 23
			S	PTFE conductive	-	7 15 06 24	7 25 06 24	-
7	2	O-ring, diaphragm outer	T, H, E, S	FKM	7 10 070 09	7 15 070 09	7 25 070 09*	7 32 070 09***
8	2	Gasket diaphragm	T, H, E, S	PTFE	7 10 071 23	7 15 071 23	7 25 071 23*	7 32 071 23***
9	2	Union nut	T	PE	7 10 05 20	7 15 05 20	7 25 05 20	7 32 05 20
			H	PEEK	7 10 05 55	7 15 05 55	-	-
			E	PA	7 10 05 40	7 15 05 40	7 25 05 40	7 32 05 40
			S	AISI 304	-	7 15 05 53	7 25 05 53	-
10	2	O-ring, union nut	T, H, E, S	FKM	7 10 77 09	7 15 77 09	7 25 77 09*	7 32 77 09***
11	8	Damper ring	T, H, E, S	FKM	7 10 49 09	7 10 49 09	7 10 49 09	7 10 49 09***
12	2	Sliding ring	T, H, E, S	PTFE	7 10 92 23	7 15 92 23*	7 25 92 23*	7 32 92 23***
13	1	Air valve, cpl.	T, H, E, S	PETP	7 10 020 31	7 15 020 31	7 25 020 31*	7 32 020 31***
14	1	Cascade sleeve	T, H, E, S	TFM/PTFE	7 10 040 05	7 15 040 05	7 25 040 05*	7 32 040 05***
15	2	Valve housing	S	AISI 316L	-	7 15 053 53	7 25 053 53	-
16	2	Piston ring, diaphragm bolt	T, H, E, S	PTFE-PPS	7 10 073 18	7 15 073 18	7 25 073 18*	7 32 073 18***
17	1	Muffler	T, H, E, S	PE por.	7 10 99 35	7 10 99 35	7 25 99 35*	7 32 99 35***
19	2	Base frame	T, H, E	PE/ PA	7 10 04 41	7 15 04 41	7 25 04 41*	7 32 04 41***
			S	PE conductive	-	7 15 04 21	7 25 04 21	-
20	4	Anchor bolt bushing	T, H, E, S	PE	7 10 57 20	7 10 57 20	7 10 57 20*	7 10 57 20***
21	1	Diaphragm bolt, right hand	T, H, E, S	PEEK	7 10 043 55	7 15 043 55	7 25 043 55*	7 32 043 55***
22	2	Valve stop, suction valve	T, H, E	TFM/PTFE	7 10 25 05	7 15 25 05	7 25 25 05*	7 32 25 05***
23	2	O-ring, diaphragm inner	T, H, E, S	FKM	7 10 70 09	7 15 70 09	7 25 70 09	7 32 70 09***
24	1	Diaphragm bolt, left hand	T, H, E, S	PEEK	7 10 044 55	7 15 044 55	7 25 044 55*	7 32 044 55***
25	4	O-ring, air channel	T, H, E, S	FKM	7 10 076 09	7 10 076 09	7 25 076 09*	7 32 076 09***
26	4	Head screw DIN 84	T, H, E, S	PA	7 10 42 40	7 15 42 40	7 25 42 40*	7 32 42 40***
27	2	Valve stop, discharge valve	T, H, E	TFM/PTFE	7 10 55 05	7 15 55 05	7 25 55 05*	7 32 55 05***
			S	AISI 316L	-	7 15 155 53	7 25 155 53	-
28	1	Set screw DIN 551	T, H, E, S	PA	7 10 038 40	7 10 038 40	7 25 038 40*	7 32 038 40***
29	1	Plug with O-ring	T, H, E, S	PA,/FEP-FKM	7 10 48 40	7 10 48 40	7 10 48 40*	7 10 48 40***
30	1	Adapter, muffler	T, H	PE	7 10 046 20	-	-	-
32	1	Air valve cover	T, H, E, S	PE	7 10 059 20	7 10 059 20	7 25 059 20*	7 32 059 20***
33	4	Head screw DIN 84	T, H, E, S	PA	7 10 046 40	7 10 046 40	7 10 046 40*	7 10 046 40***

\* - only for: DMS 50 T, E

\*\* - for DMS 10 E

\*\*\* - only for DMS 100 T, E

**Exploded view**

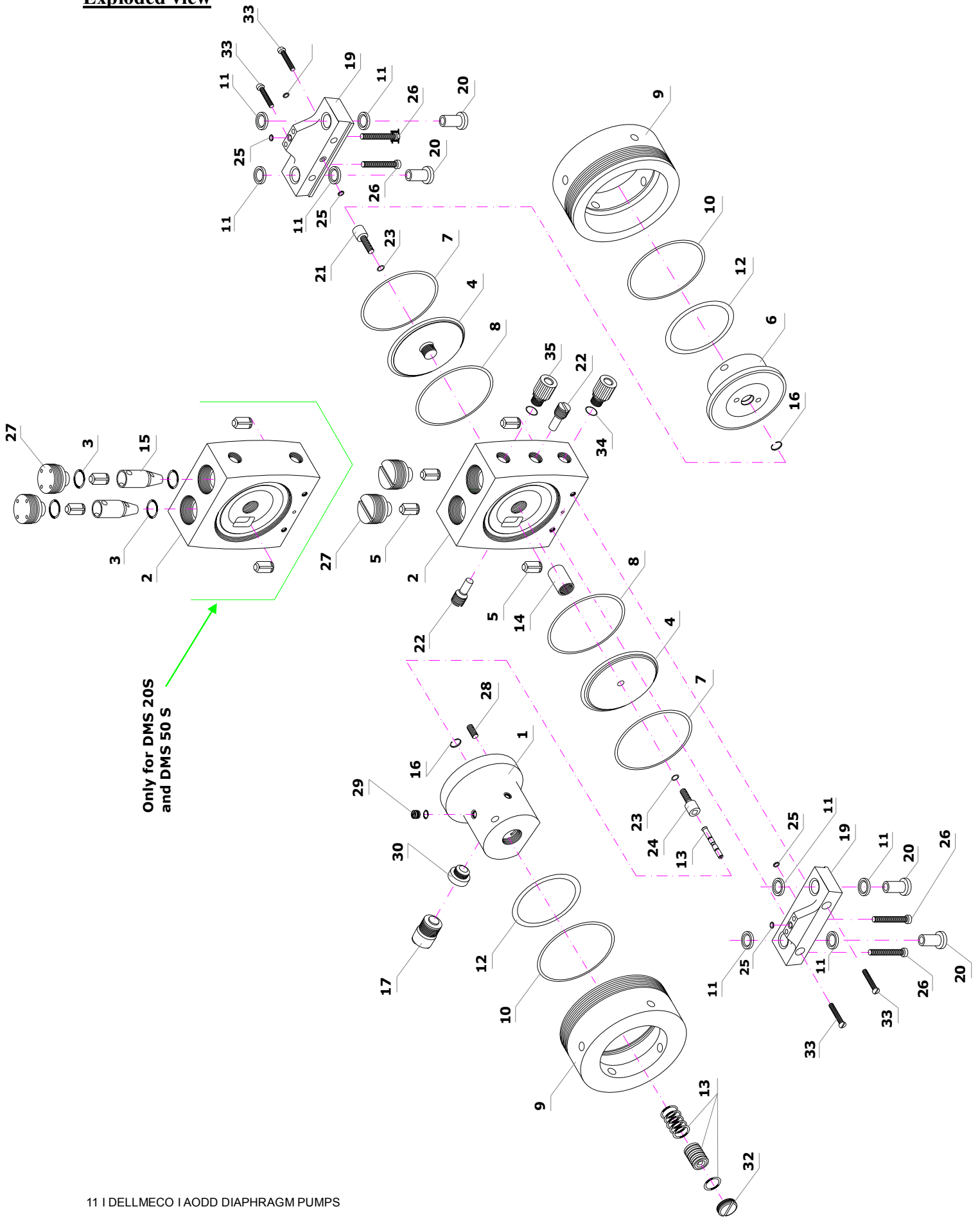

## **Additional equipment**

### **Pneumatic stroke counting system (code SC5, SC6)**

The strokes of the pump will be automatically counted after introducing the codes SC5 and SC6. The pressure change in the air chamber behind one of the diaphragms will be noted by the pressure switch. To function well, the counting system must be fed with the pressure of at least 1.5 bar.

The two types of the counting system are:

- **SC5** - pressure switch 1 - 10 bar, cpl. assembled with socket with cable 5 m; adapter straight NPT ¼"; hose DN 4/6, 2.5 m
- **SC6** - as **SC5** and a stroke counter.

The steps for assembling the pneumatic stroke counting are as follows:

1. Take the plug [29] out of the extra air connection in the left side housing [1] and screw in the adapter straight (the location of the plug is presented in the picture).
2. Put a hose linking the adapter straight with the pressure switch.
3. The socket must be now connected to the electrical connection plug of the pressure switch.
4. The cable is to be connected to an already existing registering device (in case of SC5) or the enclosed stroke counter (in case of SC6).

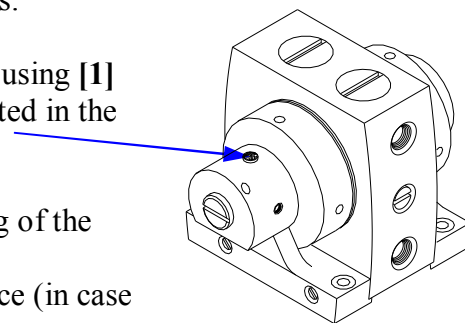

For details, refer to the technical data and installment schemes supplied by the producer of the counter.

### **Diaphragm sensor (code DM1, DM3, DM4)**

The role of the diaphragm sensor is to detect a diaphragm fracture. It is installed in the muffler and is designed to be able to operate for any liquid. There are three types of diaphragm sensors:

- DM1: 2-wire-Namur, intrinsically safe EEx ia IIC T6
- DM3: 3-wire
- DM4: 3-wire with plug (only for pumps sizes 10, 20, 50)

! A false alert may sometimes occur due to humid surroundings.

For details, refer to the technical data supplied by the producer of the sensor.

### **Flaretek© - connectors for PFA pipe (code CF)**

Flaretek©-connectors can be used with the SEMI T and SEMI H pumps in their suction and discharge ports.

! Flaretek© - connectors are installed by the producer. No one else is authorized to remove or replace them. The violation of this point will jeopardize the purity and proper work of the pump, and will invalidate the warranty!

## Spare part list for additional equipment

Pump size					SEMI 10	SEMI 20	SEMI 50	SEMI 100	
Code	It.	Pc.	Description	Pump code	Material	Part no.	Part no.	Part no.	Part no.
SC5	-	1	Adaptor straight	T, H, E, S	PP	1 08 192 28	1 08 192 28	1 08 192 28	1 08 192 28
	-	1	Hose	T, H, E, S	PE	1 08 292 20	1 08 292 20	1 08 292 20	1 08 292 20
	-	1	Pressure transmitter	T, H, E, S	diverse	9 08 28 00	9 08 28 00	9 08 28 00	9 08 28 00
	-	1	Socket with cable	T, H, E, S	diverse	1 08 392 00	1 08 392 00	1 08 392 00	1 08 392 00
SC6			As SC5 but additionally contains:						
	-	1	Stroke counter	T, H, E, S	diverse	9 15 17 00	9 15 17 00	9 15 17 00	9 15 17 00
DM1	-	1	Diaphragm sensor, 2-wire Namur	T, H, E, S	diverse	9 15 19 00	9 15 19 00	9 15 19 00	9 15 19 00
DM3	-	1	Diaphragm sensor, 3-wire	T, H, E, S	diverse	9 15 019 00	9 15 019 00	9 15 019 00	9 15 019 00
DM4	-	1	Diaphragm sensor, 3-wire with plug	T, H, E, S	diverse	9 15 119 00	9 15 119 00	9 15 119 00	
CF	35	2	Flaretek® Connector for PFA- pipe	T	PFA/PVDF	7 10 95 44	7 20 95 44	7 50 95 44	7 100 95 44
	35	2	Flaretek®-connector for PFA pipe	H	PFA/PFA	7 10 95 43	7 20 95 43	7 50 95 43	7 100 95 43
	34	2	O-ring, Flaretek®-connector	T, H	FEP/FKM	7 10 095 04	7 20 095 04	7 50 095 04	7 100 095 04

## SEMI pumps summary

**Model:** SEMI T  
**Materials:** center housing: TFM/PTFE; side housings: UPPE/PA  
**Pump sizes:** 10, 20, 50, 100  
**Products:** acids and caustics

**Model:** SEMI H  
**Materials:** center housing: TFM/PTFE; side housings: PTFE  
**Pump sizes:** 10, 20  
**Products:** hot applications with acids and caustics

**Model:** SEMI E  
**Materials:** center housing: UPPE; side housings: UPPE/PA  
**Pump sizes:** 10, 20, 50, 100  
**Products:** slurries

**Model:** SEMI S  
**Materials:** center housing: SS 316 L; side housings: PTFE conductive  
**Pump sizes:** 20, 50  
**Products:** solvents

**OPERATION MANUAL – PULSATION DAMPER FOR SEMI PUMPS**  
**TYPES: D 10T/ 20T/ 50T**  
**D 10H/ 20H**  
**D 20S, D 50S**

**!** The manual must be studied carefully before installing a damper.

DELLMECO is a distinguished, certified enterprise, aiming at modernity and best quality of our products.

The SEMI pumps are specially designed to reduce a pulsating flow, typical of replacement pumps. However, if the remaining pulsation does not achieve a satisfactory level, we offer a range of dampers. Type **D** is suitable for all sizes and configurations of the SEMI pumps.

Every single damper undergoes a strict control process and is delivered in a separate packaging to maintain the highest purity standards.

**!** Remember that depending on the phase of process a pulsation damper can reduce the over-  
whole capacity of the system!  
**!** Make sure that the construction materials of a damper are resistant to the medium to be pumped!

### **Installing procedure**

The special design of a pulsation damper allows to install it at any time in order reduce the unsatisfactory pulsation on the discharge side, with no interference into product connections.

The steps for installation are as follows:

1. Remove the discharge stop valve at the front of the pump.
2. Set the pump upright on its feet and see if the check valve of the pump is in a correct position.
3. See if the damper housing O-ring [37] is in a correct position in the groove.
4. Gently screw the damper to the pump. Be careful not to tighten too much – otherwise a damage of the thread may follow!

**!** Do not install any valves or stops between the pump and the air supply of the damper!  
**!** Both the pump and the damper must be fed with the same pressure!  
**•** Never operate the pump and the damper with a positive suction pressure!

The damper must have its own separate air connection in order to function well. The air connection of the damper is situated on the top of the head [38] and it should start at the air connection of the pump. The minimal counter pressure demanded for a proper work of the damper is 1 bar. For the requirements concerning the air quality, refer to the table in Technical Details section.

An empty damper must be run slowly together with the pump. The dampers are self-regulating – when the working conditions change, they adapt automatically.

## **Disassembly**

- ! To disassemble the damper, first disconnect both the pump and the damper from the air supply, empty them of the medium and rinse thoroughly.
- ! If the medium used in the pump was toxic, hazardous or corrosive, the disassembly of the damper must be carried out in accordance with adequate safety regulations.

The steps for disassembly are as follows:

1. Unscrew the damper from the pump. Be careful with the damper housing O-ring [37]!
2. Unscrew the damper housing [36] from the damper head [38].
3. Gently take the diaphragm outer O-ring [46].
4. Take out the diaphragm [44] together with an actuator shaft [48]
5. Take the diaphragm gasket [47] out.
6. See if the diaphragm inner O-ring [45] is intact. If necessary, replace it to prevent twisting.
7. Take the piston rings [40] and their O-rings [41].
8. Take the damper head O-ring [39] out.

## **Assembly**

- ! After disassembly, no piston rings [40] or gaskets [47] can be used again – new rings must be set in!
- All damaged or dirty sealing parts must be replaced!

Remember that the newly changed damper diaphragm gasket [47] needs some time to settle, therefore the assembly must be completed at least 2 hours before screwing the damper back to the pump. After the two-hour rest tighten the housing parts [36]. The damper is now ready to be installed back onto the pump.

Basically, assembly is carried out in reverse order to disassembly. There are however a few points to follow when assembling the new piston rings [40]:

1. Bend the new piston ring [40] into a kidney shape. Put it into the groove.
2. Press the protruding part into the groove with the help of a round tool.
3. Place the diaphragm outer O-ring [46] in the right groove of the diaphragm [44].
4. Put the diaphragm [44] back in its place.

## Technical details

Damper code	D 10/ 20/ 50/ 100 T for SEMI T				D 10/ 20 H for SEMI H		D 10/ 20/ 50/ 100 T for SEMI E				D 20/ 50 S For SEMI S	
	10	20	50	100	10	20	10	20	50	100	20	50
Dimensions* [mm]:												
length	184	207	255	305	184	207	184	207	255	305	207	255
width	136	163	224	265	136	163	136	163	224	265	163	224
height	245	287	346	430	245	287	245	287	346	430	287	346
Air connection (NPT)	1/4"				1/4"		1/4"				1/4"	
Air classification (ISO-DIS 8573-1)												
Solids	class 2				class 2		class 2				class 2	
Water	class 3				class 3		class 3				class 3	
Oil	class 3				class 3		class 3				class 3	
Weight* [kg]	3,5	6	11	24	4	7	3	5	9	18	19	37
Max. permissible driving pressure [bar]	6				6		6				6	
Max. permissible temperature [°C]												
at max. 6 bar pressure	100				100		70				130	
at max. 5 bar pressure	110				130		70				130	
at max. 4 bar pressure	120				150		70				130	
at max. 3 bar pressure	130				180		70				130	
at max. 2 bar pressure	130				200		70				130	

\* dimensions and weights are given for the pump with pulsation damper

## Spare parts list

Damper size					D 10 T, H	D 20 T, H, S	D 50 T, S	D 100 T
Item	Pc.	Description	Damper code	Material	Part No.	Part No.	Part No.	Part No.
36	1	Damper housing	T, H	TFM/PTFE	8 10 701 05	8 20 701 05	8 50 701 05	8 100 701 05
			S	AISI 316L		8 20 901 53	8 50 901 53	
37	1	O-ring, damper housing	T, H	EPDM	8 10 79 08	8 20 79 08	8 50 79 08	8 100 79 08
38	1	Damper head	T	UPPE	8 10 103 22	8 20 103 22	8 50 103 22	8 100 103 22
			H	PTFE	8 10 103 23	8 20 103 23		
			S	PTFE conductive		8 20 903 24	8 50 903 24	
39	1	O-ring, damper head	T, H	FKM	8 10 179 09	8 20 179 09	8 50 179 09	8 100 179 09
40	3	Piston ring	T, H	PTFE-PPS	8 10 090 18	8 20 090 18	8 50 090 18	8 100 090 18
41	3	O-ring, piston ring	T, H	FKM	8 10 082 09	8 20 082 09	8 50 082 09	8 100 082 89
42	1	Muffler	T, H	PE	8 10 099 20	8 20 099 20	8 50 099 20	8 100 099 20
43	1	Supporting disc	T, H	PA	8 10 53 40	8 20 53 40	8 50 53 40	8 100 53 40
44	1	Damper diaphragm	T, H	PTFE	8 10 052 23	8 20 052 23	8 50 052 23	8 100 053 23
45	1	O-ring, diaphragm inner	T, H	FKM	8 10 169 09	8 20 169 09	8 50 169 09	8 100 169 09
46	1	O- ring, diaphragm outer	T, H	FKM	8 10 170 09	8 20 170 09	8 50 179 09	8 100 179 09
47	1	Diaphragm gasket	T, H	PTFE	8 10 171 23	8 20 171 23	8 50 171 23	8 100 171 23
48	1	Actuator shaft.	T, H	PEEK	8 10 140 55	8 20 140 55	8 50 140 55	8 100 140 55



**Exploded view – pulsation damper for SEMI pumps**

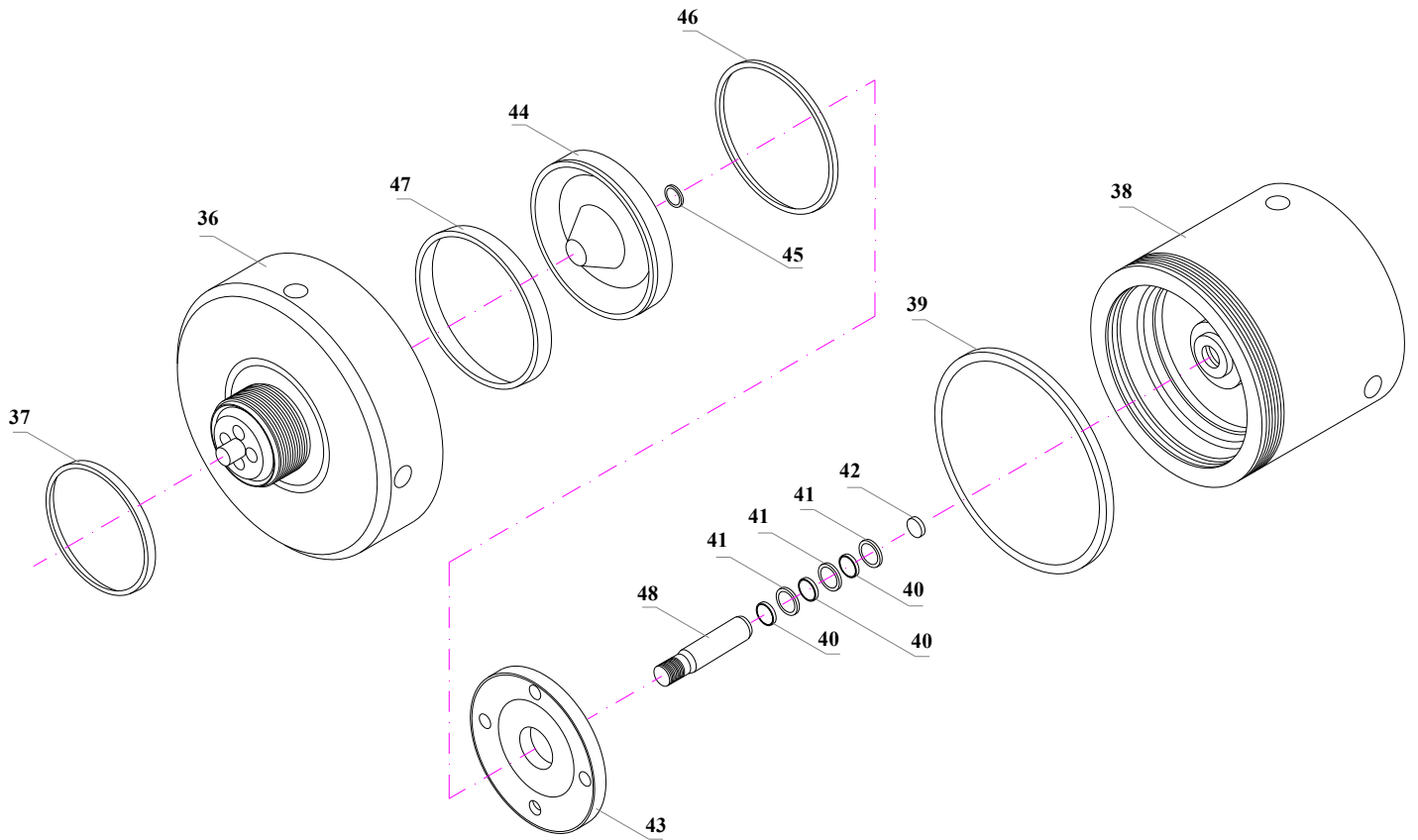

**Plastic SEMI pump with Pulsation damper – main dimensions**

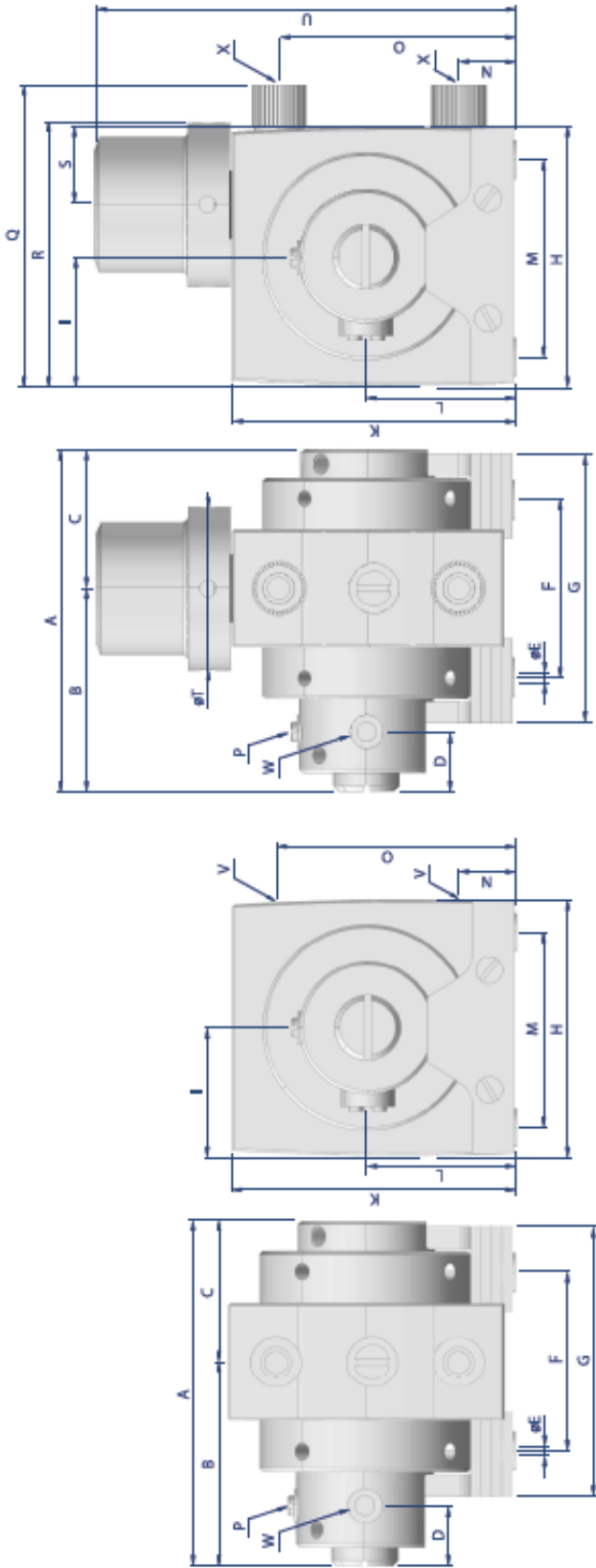

mm	A	B	C	D	E	F	G	H	I	K	L	M	N	O	Q	R	S	T	U	V	W	X
<b>SEMI 10</b>	184,0	112,0	72,0	28,0	10,5	95,0	145,0	114,0	57,0	133,0	68,0	79,5	37,0	105,0	155,0	155,0	36,0	110,0	245,0	3/8" NPT	1/4" NPT	3/8"
<b>SEMI 20</b>	207,0	109,0	98,0	35,0	10,5	109,0	163,0	154,0	75,0	172,0	91,0	115,0	32,0	139,0	200,0	163,0	46,0	110,0	287,0	1/2" NPT	1/4" NPT	1/2"
<b>SEMI 50</b>	255,0	157,0	98,0	46,0	19,0	113,0	195,0	207,0	104,0	215,0	110,0	165,0	33,0	177,0	258,0	224,0	59,0	150,0	346,0	1" NPT	1/4" NPT	1"
<b>SEMI 100</b>	315,0	196,0	119,0	57,0	19,0	138,0	238,0	269,0	135,0	267,0	138,0	225,0	39,0	223,0	322,0	298,0	80,0	213,0	428,0	1 1/4" NPT	1/4" NPT	1 1/4"

inches	A	B	C	D	E	F	G	H	I	K	L	M	N	O	Q	R	S	T	U	V	W	X
<b>SEMI 10</b>	7,2	4,4	2,8	1,1	0,4	3,7	5,7	4,5	2,2	5,2	2,7	3,1	1,5	4,1	6,1	6,1	1,4	4,3	9,6	3/8" NPT	1/4" NPT	3/8"
<b>SEMI 20</b>	8,1	4,3	3,9	1,4	0,4	4,3	6,4	6,1	3,0	6,8	3,6	4,5	1,3	5,5	7,9	6,4	1,8	4,3	11,3	1/2" NPT	1/4" NPT	1/2"
<b>SEMI 50</b>	10,0	6,2	3,9	1,8	0,7	4,4	7,7	8,1	4,1	8,5	4,3	6,5	1,3	7,0	10,2	8,8	2,3	5,9	13,6	1" NPT	1/4" NPT	1"
<b>SEMI 100</b>	12,4	7,7	4,7	2,2	0,7	5,4	9,4	10,6	5,3	10,5	5,4	8,9	1,5	8,8	12,7	11,7	3,1	8,4	16,9	1 1/4" NPT	1/4" NPT	1 1/4"

W – air supply P = 1/4" NPT air supply for pneumatic diaphragm stroke counting X = pipe outer diameter special equipment FLARETEK©

**Notes:**

A large grid of graph paper for taking notes. The grid consists of 20 columns and 30 rows of small squares. The corners of the grid are rounded.

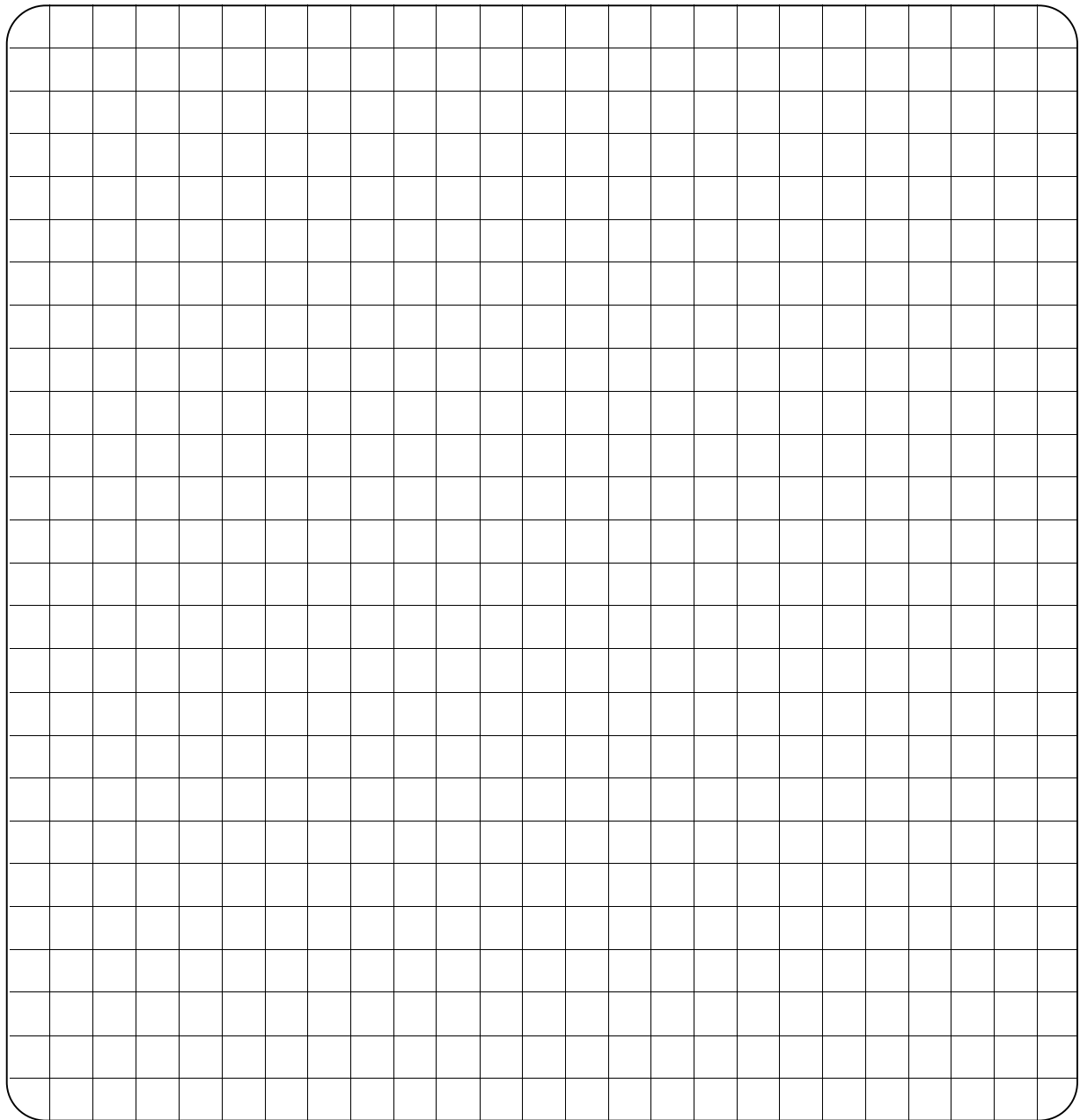

**DELLMECO LTD**

Unit 1, Willow Row  
Longton  
Stoke on Trent  
Staffordshire  
ST3 2 PU  
United Kingdom  
tel. +44 1782 793 029  
fax: +44 1782 501 721

[sales@dellmeco.com](mailto:sales@dellmeco.com)  
[www.dellmeco.com](http://www.dellmeco.com)

